

Land Use Consent Application For Works in or on the Beds of Lakes and Rivers

The information you supply should be detailed according to the scale, scope and potential effects of the proposed activity.

Please answer all questions fully. It is recommended that you discuss your application with a Council consents officer prior to filling out this form.

Show the location of the activity and the adjoining properties on your map attached to Form 1. Include any relevant design plans and details of the proposed activity with this application.

Part A: General

1. National Environmental Standards for Freshwater

a) Is this an application under the National Environmental Standards for Freshwater? **Yes No**

b) If you answered yes above, what Regulation(s) of the NES Freshwater are you breaching and why?

.....

c) Is your activity for the placement, use, alteration, extension or reconstruction of a:

- Culvert
- Weir
- Flapgate
- Dam
- Ford

2. Type of Activity

b) What do you propose to do and why? (eg. Construct ford, divert creek, rock protection works)

.....

- | | |
|--------------------------------------------------------------------------------------------------------------------------------------------------------------------------------------------------------------------------------------------------------------------------------------------------------|----------------------|
| c) Will your activity involve: | Yes No |
| <ul style="list-style-type: none"> • Erecting, reconstructing, placing, altering, extending, removing, or demolishing any structure? • Excavating, drilling, tunnelling or disturbing the bed? • Depositing any substance? • Reclaiming or draining the bed? | |

3. Programme

- a) What is the proposed commencement date of the work?.....
- b) What is the proposed completion date of the work?.....
- c) What is the requested expiry date for the consent?.....
- d) Who will be undertaking the work?.....
- e) What are the proposed hours of operation/construction?.....

4. Site Details

- a) Name of the stream/river where the activity will occur? (If the waterway is an unnamed tributary then give the name of the stream/river it flows into)
.....
- b) What is the scale of the proposal?
 - Area of stream/river bed affected:(m²)
 - Length of works (eg if rock protection work)(m)

Part B: Description of Proposal

1. Describe how the work will be carried out:

.....

.....

.....

.....

.....

.....

.....

For structures – describe the general design of the structure or works required in the watercourse, the materials to be used including fill, and the construction methods to be employed.
If there are engineering plans of the proposed structure or plans of the works please enclose a copy with the application. If a diagram will assist in describing the proposal, include one on a separate page and attach it to this application form.

.....

.....

.....

.....

2. Will the work be completed out in stages?

Yes

No

If yes, describe the stages.

.....
.....
.....
.....
.....
.....

3. Is the work permanent or temporary?

Permanent

Temporary

4. What methods will be used to ensure the works, particularly structures, will provide for fish passage both during construction and operation and how will you ensure fish passage is maintained for the life of the works?

.....
.....
.....
.....
.....

5. Are the works designed to prevent the passage of certain fish species? If so detail what species and why.

.....
.....
.....
.....

6. Describe how your works will impact the flood carrying capacity of the waterbody (i.e. culverts)? Are they sufficiently sized and how has this been calculated? Should they fail what potential effects could this have on the environment and neighbours?

.....
.....
.....
.....
.....

7. Are your works designed to deflect flows and if so in what way?

.....
.....
.....
.....
.....

8. If your works are to alter, extend or reconstruct a structure, please provide colour photographs of the existing structure.

Part C: Assessment of Effects on the Environment

Where your activity could have a significant adverse effect on the environment a more detailed environmental assessment is required in accordance with the Fourth Schedule of the Resource Management Act 1991. If this may be the case, you should discuss your application with a Council consents officer prior to filling out this form.

1. DESCRIPTION OF THE NATURAL ENVIRONMENT

Our environment is made up of many components. Completing this section helps identify issues relating to the proposal.

Describe the following aspects of the environment in the immediate vicinity of the proposal and the effects on them of your proposal.

- a) Bed width
.....
- b) Bed material (eg. rocky, silty)
.....
- c) Bank material
.....
- d) Any biota (eg, fish, eels, insect life)
.....
- e) The flow in the stream/river will any works or structure affect this? Is it ephemeral?
.....
- f) The water quality
.....
- g) Any Scheduled or natural wetlands and their proximity
.....

2. DESCRIPTION OF THE HUMAN AND BUILT ENVIRONMENT

Describe the following aspects of the environment and the approximate distance from them to the location of your proposed activity.

- a) Any built structures such as bridges, culverts, roads, buildings or other riverbed structures etc
.....
- b) Location and proximity of neighbours to the proposal
.....
- c) Areas of aesthetic or scientific value (eg. archaeological sites, historic sites, scenic waterfalls)
.....
- d) Recreational activities carried out (eg. swimming, walking, fishing, canoeing)
.....
- e) Areas or aspects of significance to iwi
.....
- f) Any lawful water takes downstream of the proposed works
.....

3. DESCRIPTION OF EFFECTS

Describe what effects your proposed activity may have and the steps you propose to take to mitigate these effects (eg. sediment control, erosion work). Also identify any safeguards and contingency plans where relevant.

.....
.....
.....
.....
.....
.....
.....
.....
.....

Part C: Assessment of Effects on the Environment (continued)

4. ALTERNATIVE LOCATIONS AND METHODS

a) Are there any alternative locations for carrying out the work? **Yes** **No**
If Yes, where are the alternative locations and why did you choose this location?

.....
.....
.....
.....

b) Are there any alternative methods for carrying out the work? **Yes** **No**
If Yes, what are the alternative methods and why did you choose this method?

.....
.....
.....
.....

5. MONITORING

What sort of monitoring do you propose to undertake:

a) While carrying out the activity?

.....
.....
.....

b) Following completion of the activity?

.....
.....
.....

Construction of a Bridge

Fill in the dimensions on the diagram in the list below (if the bridge design is different from that below please include a diagram showing all dimensions).

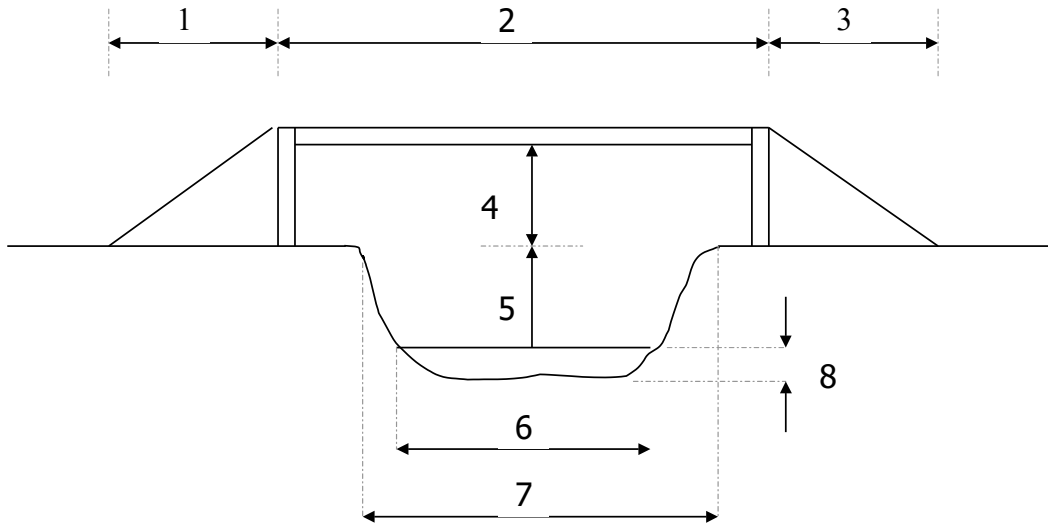

- | | |
|----------------------------------------------------------|--------------|
| 1. Length of bridge approach | _____ metres |
| 2. Length of bridge | _____ metres |
| 3. Length of bridge approach | _____ metres |
| 4. Height of bridge underside above natural ground level | _____ metres |
| 5. Height of natural ground level above stream bed | _____ metres |
| 6. Bed width of stream channel | _____ metres |
| 7. Top width of stream | _____ metres |
| 8. Average depth of water in the stream | _____ metres |

Will the abutments of the bridge be outside the banks of the waterway, in the banks of the waterway or in the bed of the waterway? Explain below.

Construction of a Culvert

Fill in the dimensions on the diagram in the list below (if the culvert design is different from that below please include a diagram showing all dimensions).

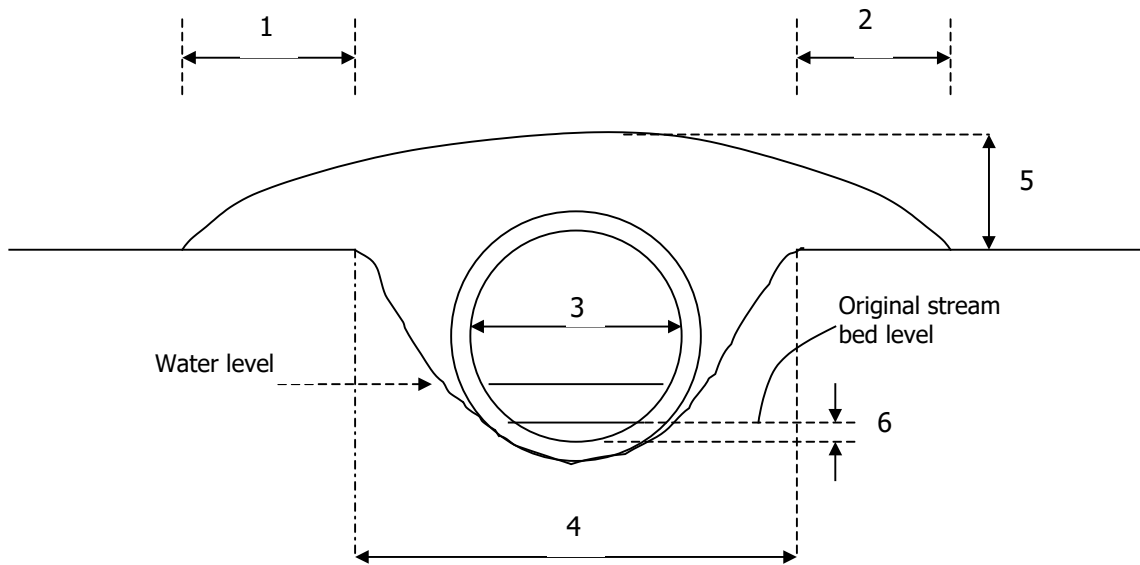

- | | |
|----------------------------------------------------------|--------------|
| 1. Length of culvert approach | _____ metres |
| 2. Length of culvert approach | _____ metres |
| 3. If circular culvert, diameter of culvert | _____ metres |
| If box culvert, width of culvert | _____ metres |
| If box culvert, height | _____ metres |
| 4. Top width of original stream | _____ metres |
| 5. Depth of fill over culvert | _____ metres |
| 6. Depth of culvert base below original stream bed level | _____ metres |

What is the proposed culvert to be made of? _____

What is the length of the culvert you intend to place in the stream? _____

At what gradient will the culvert be laid in the stream bed? _____

What is the fill material to be used over the culvert? _____

Will the culvert be open bottomed? _____